



# EVERLIGHT ELECTRONICS CO.,LTD.

DEVICE NUMBER : DLE-282-082  
ECN : \_\_\_\_\_

REV : 1.1  
PAGE : 1/5

## 1.3 mm Height Subminiature , Axial Flat Top LEDs

MODEL NO : 28-21UYC/S530-A2/TR8

### Features :

- Compatible with automatic placement equipment.
- Compatible with infrared and vapor phase reflow solder process.
- I.C. compatible.
- EIA std package.
- Mono-color type.

### Descriptions :

- The 28-21 SMD taping is much smaller than leaded components. Thusenable smaller board size.Higher packing density. Reduced storage space and finally smaller equipment to be obtained.
- Besides, light weight makes them ideal for miniature application, etc.
- Furthermore by automation assembly machines the accuracy is anticipated.

### Applications :

- Small indicator for outdoor appications.
- Flat backlight for LCD, switch and symbol.
- Indicator and backlight in office equipment.
- Indicator and backlight for battery driven equipment.
- Indicator and backlight for audio and video equipment.
- Automotive : backlighting in dashboard and switch.
- Telecommunication : indicator and backlighting in telephone and fax.
- General use.

### Package Dimensions :

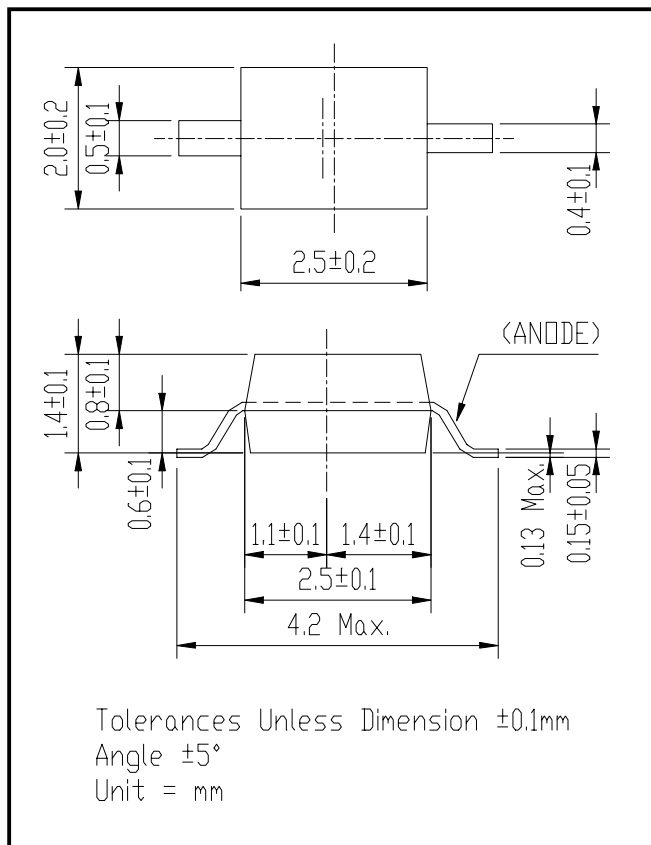

PART NO.	CHIP		Lens Color
	Material	Emitted Color	
28-21UYC/S530-A2/TR8	AlGaInP	Super Yellow	Water Clear

OFFICE : NO. 25,Lane 76,Sec.3, Chung Yang Rd., Tucheng 236, Taipei, Taiwan, R.O.C.

TEL : 886-2-2267-2000,2267-9936

FAX : 886-2-2267-6244,22676189,22676306

<http://www.everlight.com>

**1.3 mm Height Subminiature , Axial Flat Top LEDs**

MODEL NO : 28-21UYC/S530-A2/TR8

**Package Dimensions**

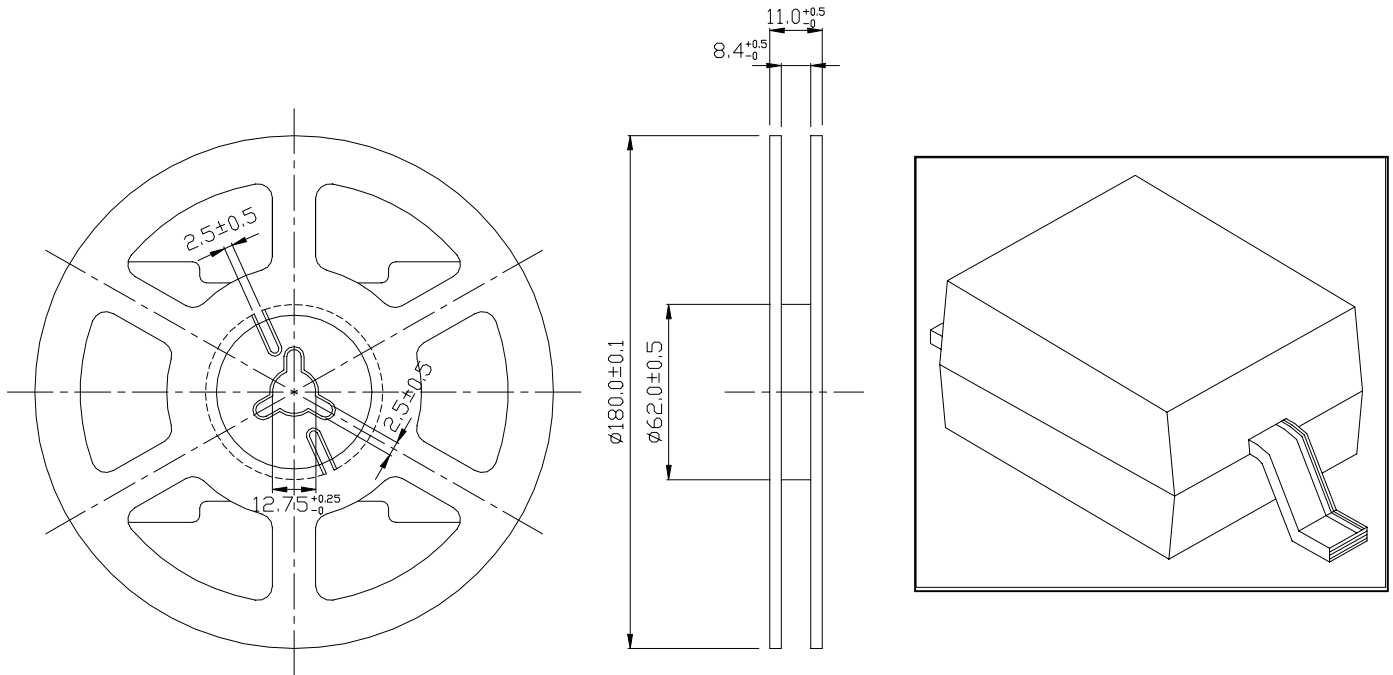

**Loaded Quantity Per Reel 2000 Pcs/Reel**

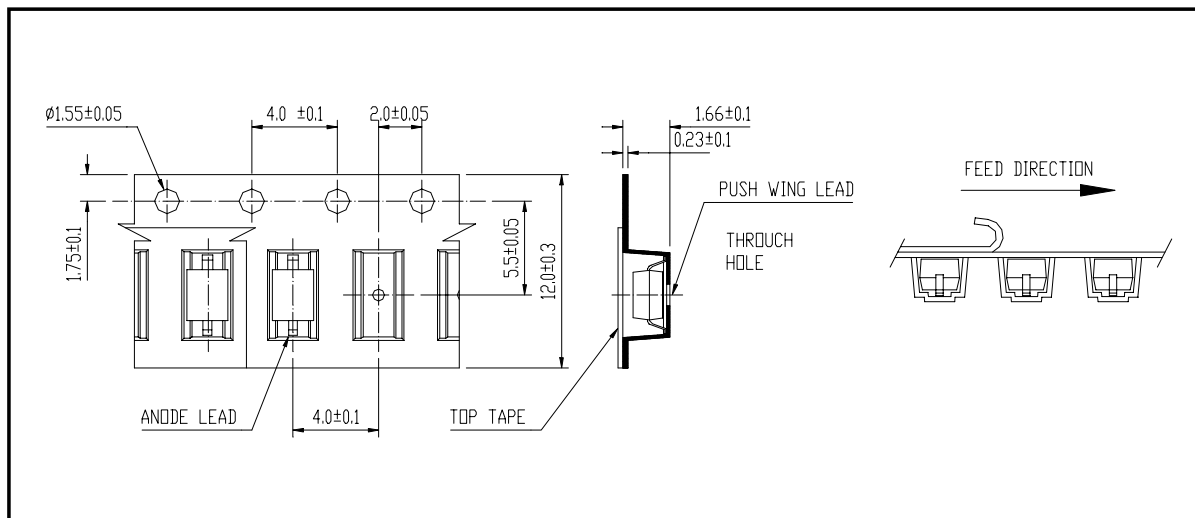

1. All dimensions are in millimeters.
2. Lead spacing is measured where the lead emerge from the package
3. Protruded resin under flange 1.5 mm (0.59") max.

**1.3 mm Height Subminiature , Axial Flat Top LEDs**

MODEL NO : 28-21UYC/S530-A2/TR8

**■ Absolute Maximum Ratings at Ta = 25°C**

Parameter	Symbol	Rating	Unit
Reverse Voltage	Vr	5	V
Forward Current	If	25	mA
Operating Temperature	Topr	-40 ~ +85	°C
Storage Temperature	Tstg	-40 ~ +100	°C
Soldering Temperature	Tsol	260 ± 5 for 5 sec	°C
<b>Electrostatic Discharge</b>	ESD	2000	V
Power Dissipation	Pd	60	mW
Peak Forward Current(Duty 1/10 @ 1KHZ)	If(Peak)	160	mA

**■ Electronic Optical Characteristics :**

Parameter	Symbol	MIN.	TYP.	MAX.	Unit	Condition
Luminous intensity	Iv	----	2	----	mcd	If = 2 mA
Luminous intensity	Iv	12	30	----	mcd	If = 20 mA
Viewing Angle	2θ 1/2	----	150	----	deg	
Peak Wavelength	λp	----	591	----	nm	
Dominant Wavelength	λd	----	589	----	nm	
Spectrum Radiation Bandwidth	Δλ	----	15	----	nm	
Forward Voltage	Vf	----	2.0	2.4	V	
Reverse Current	Ir	----	----	10	μA	Vr=5V



# EVERLIGHT ELECTRONICS CO.,LTD.

DEVICE NUMBER : DLE-282-082REV : 1.1

ECN : \_\_\_\_\_

PAGE : 4/5

## 1.3 mm Height Subminiature , Axial Flat Top LEDs

MODEL NO : 28-21UYC/S530-A2/TR8

### ■ Reliability Test Item And Condition

NO.	Item	Test Conditions	Test Hours/ Cycle	Sample Size	Ac/Re
1	Solder Heat	TEMP : 260°C ± 5 °C	5 sec	76 pcs	0/1
2	Temperature Cycle	H : +85°C 30 min ↑ 5 min ↓ L : -55°C 30 min	50 cycle	76 pcs	0/1
3	Thermal Shock	H : +100°C 5 min ↑ 10 sec ↓ L : -10°C 30 min	50 cycle	76 pcs	0/1
4	High Temperature Storage	TEMP. : +100°C	1000 hrs	76 pcs	0/1
5	Low Temperature Storage	TEMP. : -55°C	1000 hrs	76 pcs	0/1
6	DC Operating Life	If = 20 mA	1000 hrs	76 pcs	0/1
7	High Temperature / High Humidity	85°C / 85% R.H.	1000 hrs	76 pcs	0/1

**1.3 mm Height Subminiature , Axial Flat Top LEDs**

MODEL NO : 28-21UYC/S530-A2/TR8

**Typical Electro-Optical Characteristic Curves**

