

SMD ■ Low Power LED 45-21S/XK2C-SXXXXXXXXXXZ6/2T



Features

- PLCC-3 package
- Top view white LED
- High luminous intensity output
- Wide viewing angle
- Pb-free
- RoHS compliant

Description

The Everlight 45-21S package has high efficacy, high CRI, low power consumption, wide viewing angle and a compact form factor. These features make this package an ideal LED for all lighting applications.

Applications

- General lighting
- Decorative and Entertainment Lighting
- Indicators
- Illumination
- Switch lights

Product Number Explanation

45-21S / X K 2 C – S XX XX XX XX XX / 2T

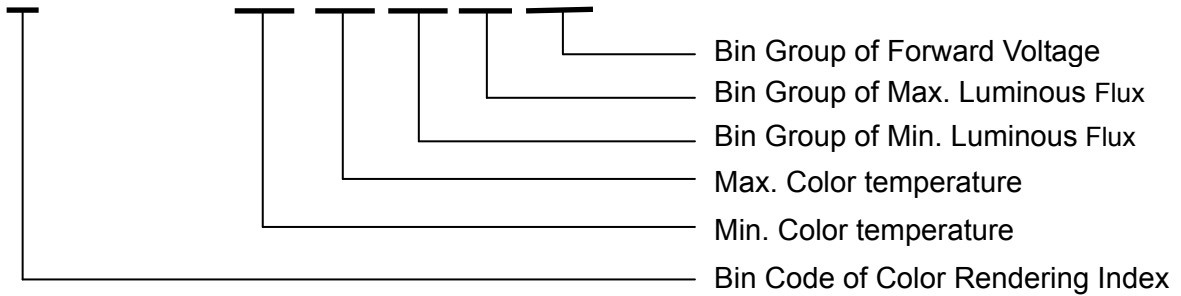

Table of Color Rendering Index

Symbol	Description
M	CRI(Min.) : 60
N	CRI(Min.) : 65
L	CRI(Min.) : 70
Q	CRI(Min.) : 75
K	CRI(Min.) : 80
H	CRI(Min.) : 90

Note:
 Tolerance of Color Rendering Index: ±2

Example:
 45-21S/LK2C-S5050L9N3B2Z6/2T

CRI	70(Min.)
CCT	5000K
Flux	18~27m
V _F	2.9~3.6V
I _F	60mA

Mass Production list

Product	CRI Min.	CCT(K)	Φ(lm) Min.	Φ(lm) Typ.	Φ(lm) Max.
45-21S/KK2C-S2727L5L7B2Z6/2T	80	2700K	14	-	17
45-21S/KK2C-S3030L6L9B2Z6/2T	80	3000K	15	-	19
45-21S/KK2C-S4040L8M4B2Z6/2T	80	4000K	17	-	24
45-21S/LK2C-S5050L9N3B2Z6/2T	70	5000K	18	-	27
45-21S/LK2C-S5757L9N3B2Z6/2T	70	5700K	18	-	27
45-21S/LK2C-S6565L9M4B2Z6/2T	70	6500K	18	-	24

Note:
Tolerance of Luminous flux: ±11%.

Device Selection Guide

Chip Materials	Emitted Color	Resin Color
InGaN	Cool White Warm White	Water Clear

Absolute Maximum Ratings ($T_{\text{Soldering}}=25^{\circ}\text{C}$)

Parameter	Symbol	Rating	Unit
Forward Current	I_F	75	mA
Peak Forward Current (Duty 1/10 @10ms)	I_{FP}	100	mA
Power Dissipation	P_d	350	mW
Operating Temperature	T_{opr}	-40 ~ +85	$^{\circ}\text{C}$
Storage Temperature	T_{stg}	-40 ~ +100	$^{\circ}\text{C}$
Thermal Resistance (Junction / Soldering point)	$R_{th\ J-S}$	50	$^{\circ}\text{C/W}$
Junction Temperature	T_j	125	$^{\circ}\text{C}$
Soldering Temperature	T_{sol}	Reflow Soldering : 260 $^{\circ}\text{C}$ for 10 sec. Hand Soldering : 350 $^{\circ}\text{C}$ for 3 sec.	

Note:

The products are sensitive to static electricity and must be carefully taken when handling products

Electro-Optical Characteristics ($T_{\text{Soldering}}=25^{\circ}\text{C}$)

Parameter	Symbol	Min.	Typ.	Max.	Unit	Condition
Luminous Flux	Φ	14	-----	27	lm	$I_F=60\text{mA}$
Forward Voltage	V_F	2.9	-----	3.6	V	$I_F=60\text{mA}$
Viewing Angle	$2\theta_{1/2}$	-----	120	-----	deg	$I_F=60\text{mA}$

Notes:

1. Tolerance of Luminous flux: $\pm 11\%$.
2. Tolerance of Forward Voltage : $\pm 0.1\text{V}$.

Bin Range of Luminous intensity

Bin Code	Min.	Max.	Unit	Condition
L5	14	15	lm	I _F =60mA
L6	15	16		
L7	16	17		
L8	17	18		
L9	18	19		
M3	19	21		
M4	21	24		
N3	24	27		

Note:
 Tolerance of Luminous flux: ±11%.

Bin Range of Forward Voltage

Group	Bin Code	Min.	Max.	Unit	Condition
B2	36	2.9	3.0	V	I _F =60mA
	37	3.0	3.1		
	38	3.1	3.2		
	39	3.2	3.3		
	40	3.3	3.4		
	41	3.4	3.5		
	42	3.5	3.6		

Note:
 Tolerance of Forward Voltage: ±0.1V.

Bin Range of Chromaticity Coordinates

CCT	Bin Code	CIE_x	CIE_y	Bin Code	CIE_x	CIE_y
2700K	27K-1	0.4813	0.4319	27K-3	0.4585	0.4104
		0.4688	0.4290		0.4468	0.4077
		0.4585	0.4104		0.4373	0.3893
		0.4703	0.4132		0.4483	0.3919
	27K-2	0.4688	0.4290	27K-4	0.4703	0.4132
		0.4562	0.4260		0.4585	0.4104
		0.4468	0.4077		0.4483	0.3919
		0.4585	0.4104		0.4593	0.3944

CCT	Bin Code	CIE_x	CIE_y	Bin Code	CIE_x	CIE_y
3000K	30K-1	0.4562	0.4260	30K-3	0.4345	0.4033
		0.4431	0.4213		0.4223	0.3990
		0.4345	0.4033		0.4147	0.3814
		0.4468	0.4077		0.4260	0.3854
	30K-2	0.4431	0.4213	30K-4	0.4468	0.4077
		0.4299	0.4165		0.4345	0.4033
		0.4223	0.3990		0.4260	0.3854
		0.4345	0.4033		0.4373	0.3893

CCT	Bin Code	CIE_x	CIE_y	Bin Code	CIE_x	CIE_y
4000K	40K-1	0.4006	0.4044	40K-3	0.3828	0.3803
		0.3871	0.3959		0.3703	0.3726
		0.3828	0.3803		0.3670	0.3578
		0.3952	0.3880		0.3784	0.3647
	40K-2	0.3871	0.3959	40K-4	0.3952	0.3880
		0.3736	0.3874		0.3828	0.3803
		0.3703	0.3726		0.3784	0.3647
		0.3828	0.3803		0.3898	0.3716

Bin Range of Chromaticity Coordinates

CCT	Bin Code	CIE_x	CIE_y	Bin Code	CIE_x	CIE_y
5000K	50K-1	0.3551	0.3760	50K-3	0.3452	0.3558
		0.3464	0.3688		0.3371	0.3493
		0.3452	0.3558		0.3366	0.3369
		0.3533	0.3624		0.3441	0.3428
	50K-2	0.3464	0.3688	50K-4	0.3533	0.3624
		0.3376	0.3616		0.3452	0.3558
		0.3371	0.3493		0.3441	0.3428
		0.3452	0.3558		0.3515	0.3487

CCT	Bin Code	CIE_x	CIE_y	Bin Code	CIE_x	CIE_y
5700K	57K-1	0.3376	0.3616	57K-3	0.3293	0.3423
		0.3292	0.3539		0.3215	0.3353
		0.3293	0.3423		0.3222	0.3243
		0.3371	0.3493		0.3294	0.3306
	57K-2	0.3292	0.3539	57K-4	0.3371	0.3493
		0.3207	0.3462		0.3293	0.3423
		0.3215	0.3353		0.3294	0.3306
		0.3293	0.3423		0.3366	0.3369

CCT	Bin Code	CIE_x	CIE_y	Bin Code	CIE_x	CIE_y
6500K	65K-1	0.3205	0.3481	65K-3	0.3131	0.3290
		0.3117	0.3393		0.3048	0.3209
		0.3131	0.3290		0.3068	0.3113
		0.3213	0.3371		0.3145	0.3187
	65K-2	0.3117	0.3393	65K-4	0.3213	0.3371
		0.3028	0.3304		0.3131	0.3290
		0.3048	0.3209		0.3145	0.3187
		0.3131	0.3290		0.3221	0.3261

Note:
 1. The value is based on driving current by 60mA.

2. Tolerance of Chromaticity Coordinates: ± 0.01 .

The C.I.E. 1931 Chromaticity Diagram

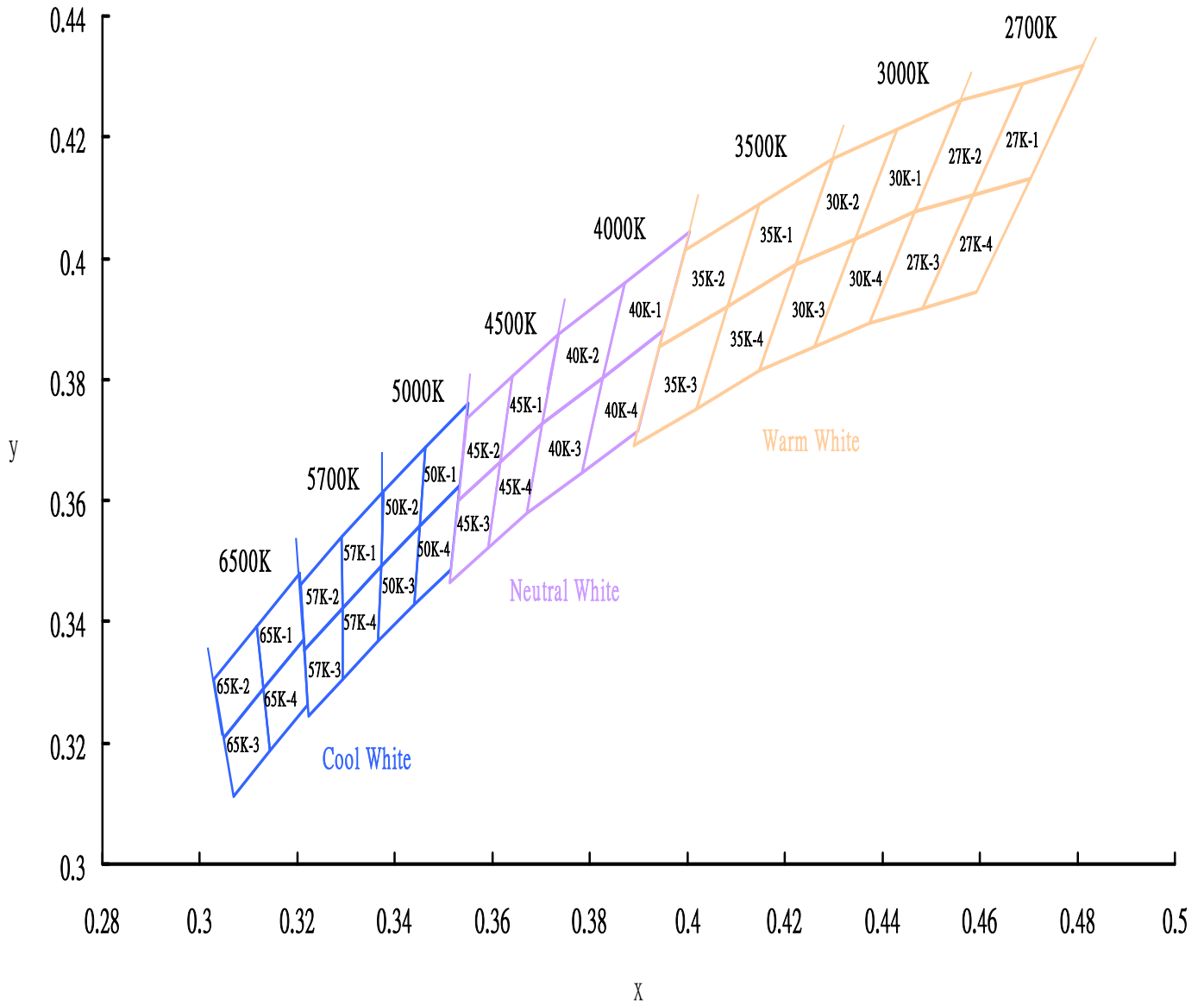

Spectrum Distribution

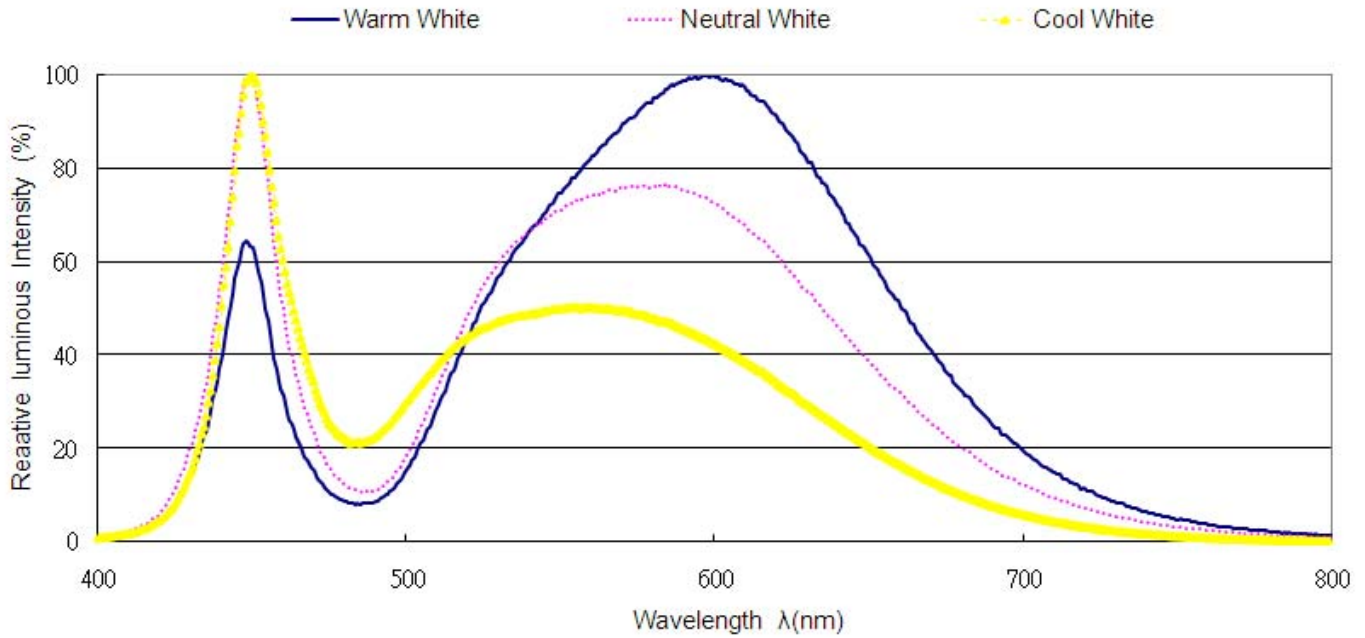

Typical Electro-Optical Characteristics Curves

Fig.1 - Forward Voltage Shift vs. Junction Temperature

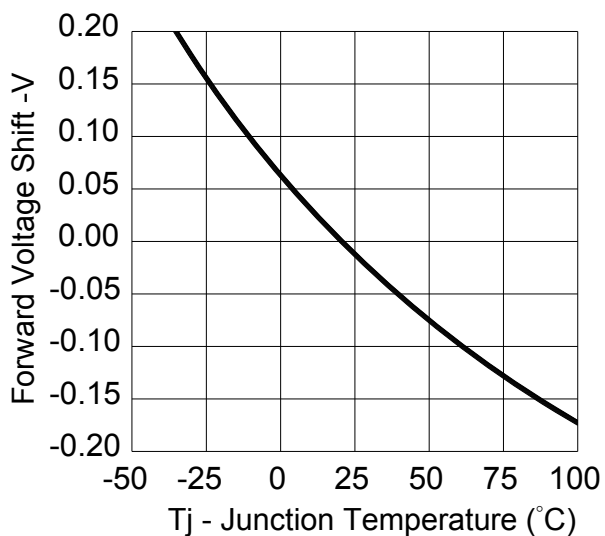
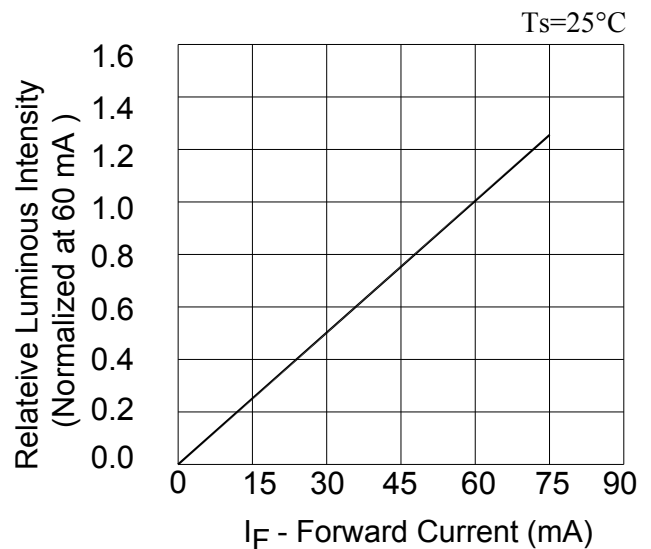

Fig.2 - Relative Luminous Intensity vs. Forward Current



Typical Electro-Optical Characteristics Curves

Fig.3 - Relative Luminous Intensity vs. Junction Temperature

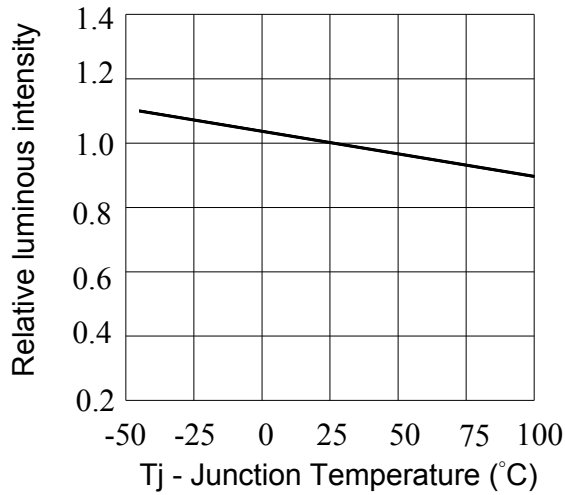

Fig.4 - Forward Current vs. Forward Voltage

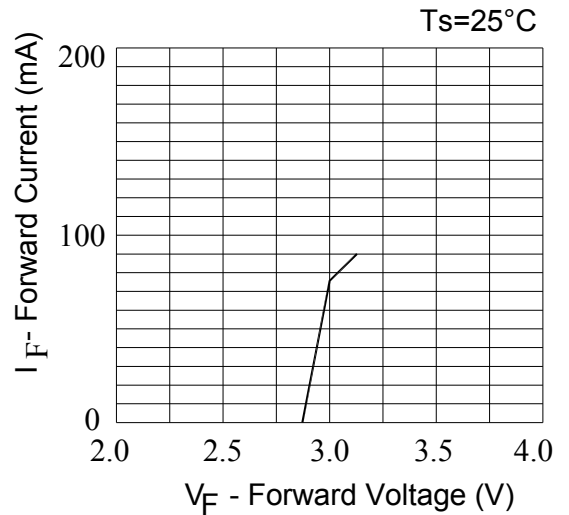

Fig.5 - Max. Driving Forward Current vs. Soldering Temperature

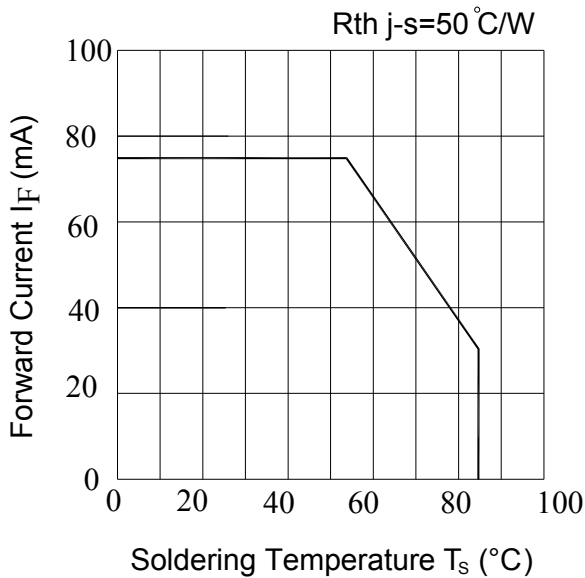
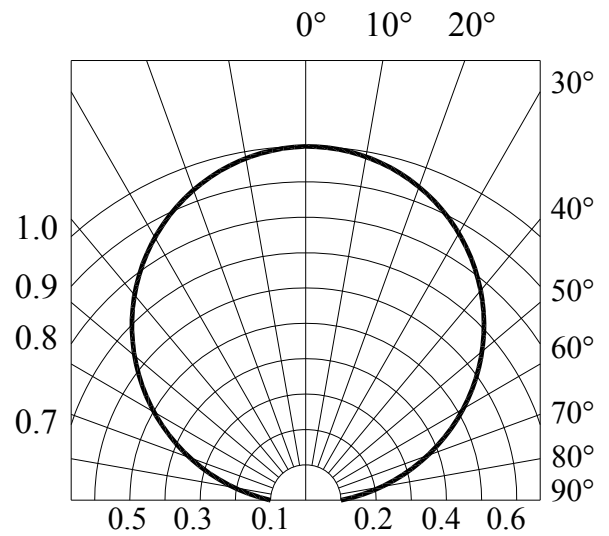
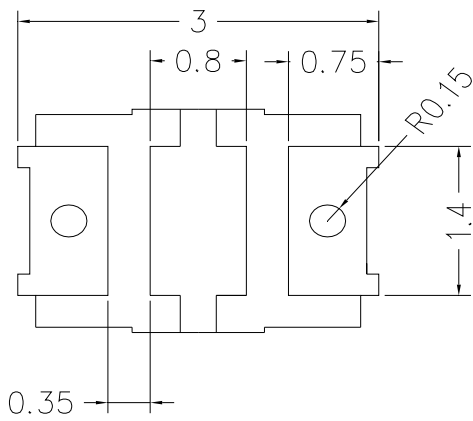
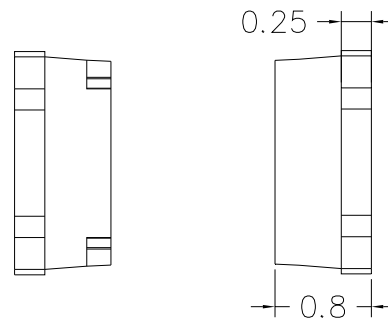
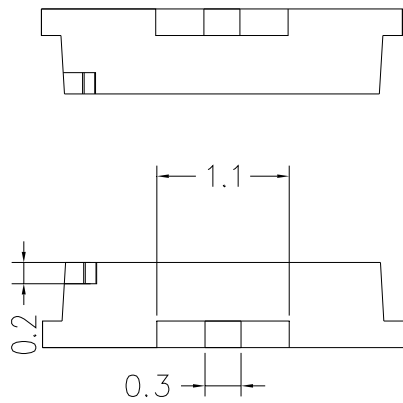
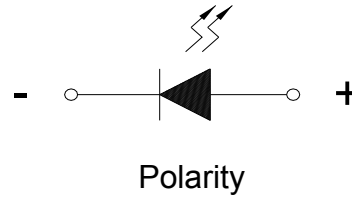
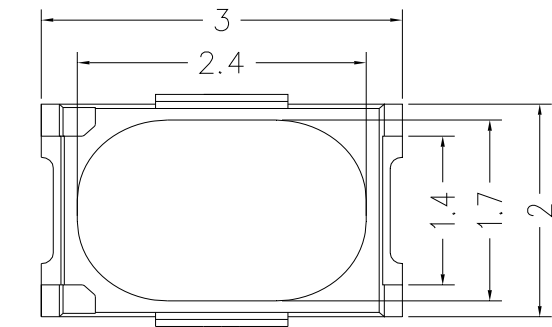

Fig.6 - Radiation Diagram



Package Dimension



Recommended Solde Pad

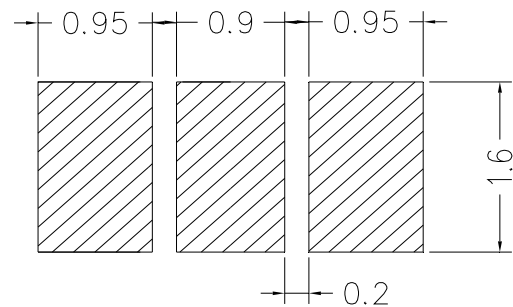

Note:
 Tolerance unless mentioned is $\pm 0.2\text{mm}$; Unit = mm

Moisture Resistant Packing Materials

Label Explanation



- CPN: Customer's Product Number
- P/N: Product Number
- QTY: Packing Quantity
- CAT: Luminous Intensity Rank
- HUE: Dom. Wavelength Rank
- REF: Forward Voltage Rank
- LOT No: Lot Number

Reel Dimensions

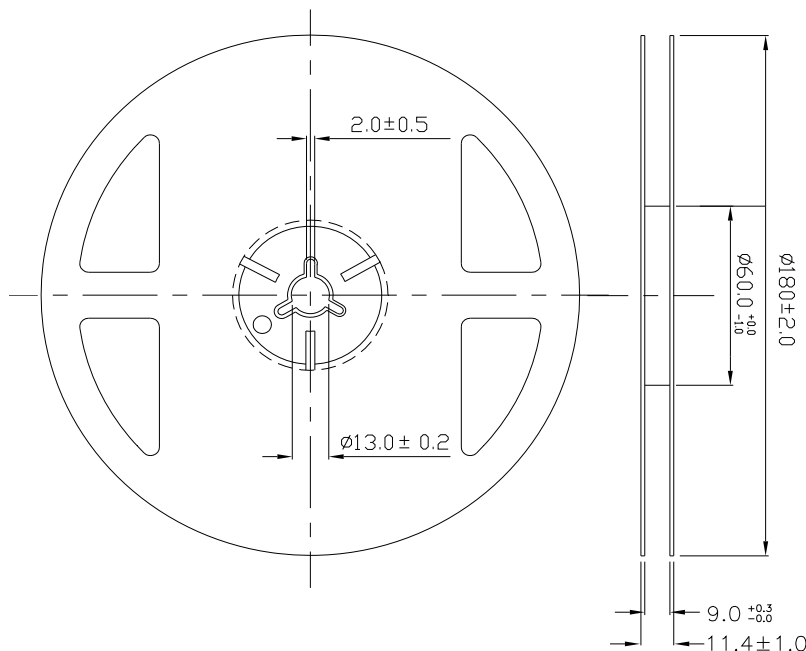

Note:
 Tolerances unless mentioned ± 0.1 mm. Unit = mm

Carrier Tape Dimensions: Loaded Quantity 2000 pcs Per Reel

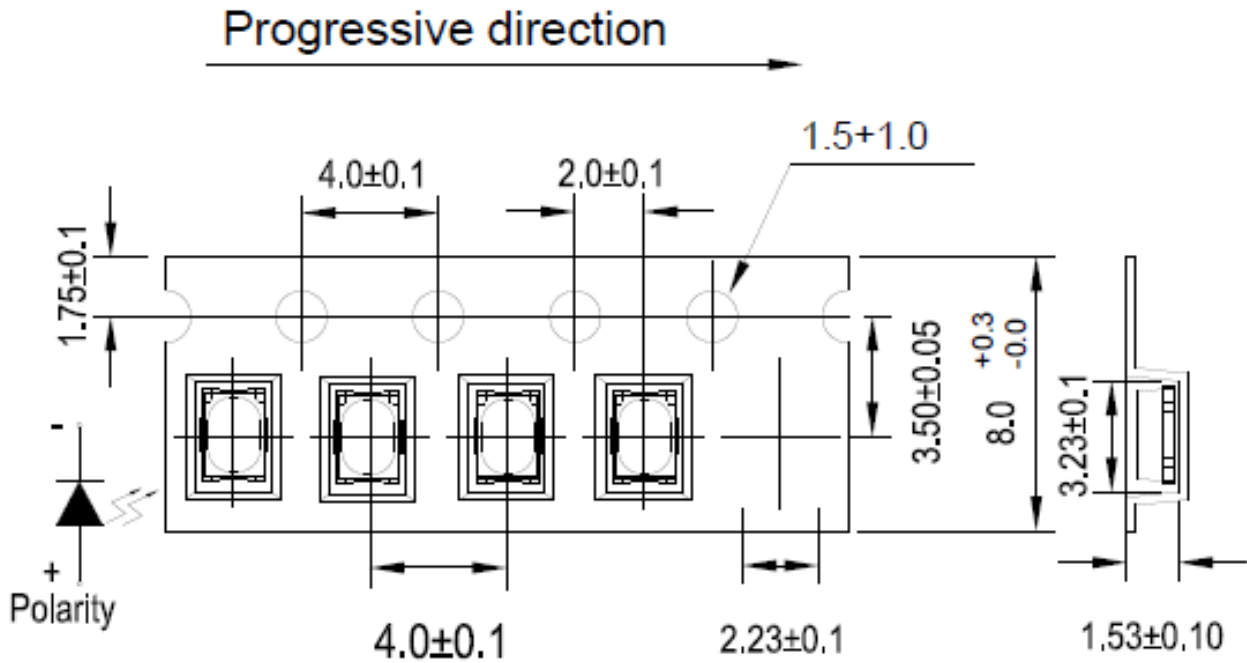

Note:
 1. Tolerance unless mentioned is ± 0.1 mm; Unit = mm
 2. Minimum packing amount is 250/500/1000/2000 pcs per reel.

Moisture Resistant Packing Process

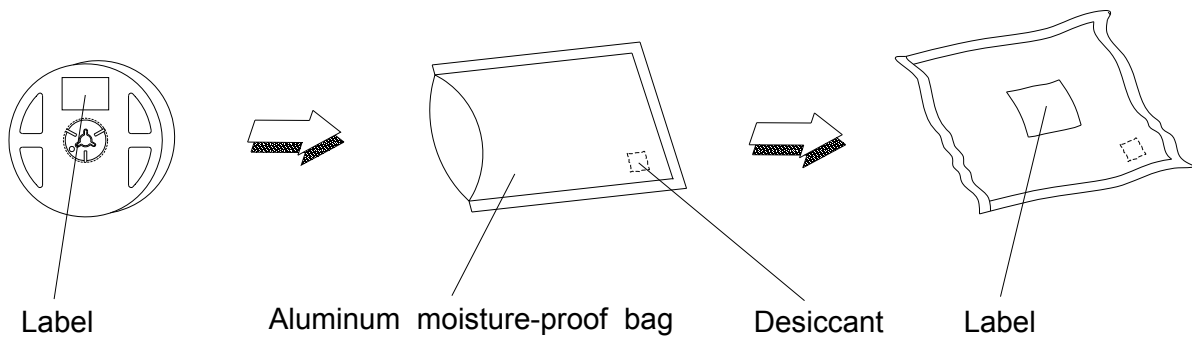

Reliability Test Items and Conditions

The reliability of products shall be satisfied with items listed below.

Confidence level : 90%

LTPD : 10%

No.	Items	Test Condition	Test Hours/Cycles	Sample Size	Ac/Re
1	Reflow Soldering	Temp. : 260°C/10sec.	6 Min.	22 PCS.	0/1
2	Thermal Shock	H : +100°C 5min ∩ 10 sec L : -10°C 5min	200 Cycles	22 PCS.	0/1
3	Temperature Cycle	H : +100°C 15min ∩ 5 min L : -40°C 15min	200 Cycles	22 PCS.	0/1
4	High Temperature/Humidity Reverse Bias	Ta=85°C,85%RH	1000 Hrs.	22 PCS.	0/1
5	High Temperature/Humidity Operation	Ta=85°C,85%RH, I _F = 75mA	1000 Hrs.	22 PCS.	0/1
6	Low Temperature Storage	Ta=-40°C	1000 Hrs.	22 PCS.	0/1
7	High Temperature Storage	Ta=85°C	1000 Hrs.	22 PCS.	0/1
8	Low Temperature Operation Life	Ta=-40°C, I _F = 75 mA	1000 Hrs.	22 PCS.	0/1
9	High Temperature Operation/ Life#1	Ta=25°C, I _F = 75 mA	1000 Hrs.	22 PCS.	0/1
10	High Temperature Operation/ Life#2	Ta=55°C, I _F =75 mA	1000 Hrs.	22 PCS.	0/1
11	High Temperature Operation/ Life#3	Ta=85°C, I _F = 30 mA	1000 Hrs.	22 PCS.	0/1

Precautions for Use

1. Over-current-proof

Customer must apply resistors for protection; otherwise slight voltage shift will cause big current change (Burn out will happen).

2. Storage

2.1 Do not open moisture proof bag before the products are ready to use.

2.2 Before opening the package: The LEDs should be kept at 30°C or less and 90%RH or less.

2.3 After opening the package: The LED's floor life is 168 Hrs under 30°C or less and 60% RH or less. If unused LEDs remain, it should be stored in moisture proof packages.

2.4 If the moisture absorbent material (silica gel) has faded away or the LEDs have exceeded the storage time, baking treatment should be performed using the following conditions.

Baking treatment: 60±5°C for 24 hours.

3. Soldering Condition

3.1 Pb-free solder temperature profile

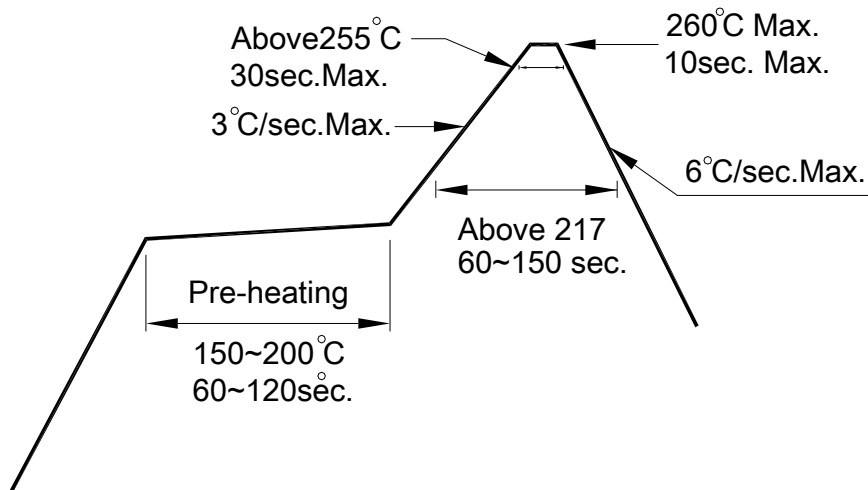

3.2 Reflow soldering should not be done more than two times.

3.3 When soldering, do not put stress on the LEDs during heating.

3.4 After soldering, do not warp the circuit board.

4. Soldering Iron

Each terminal is to go to the tip of soldering iron temperature less than 350°C for 3 seconds within once in less than the soldering iron capacity 25W. Leave two seconds and more intervals, and do soldering of each terminal. Be careful because the damage of the product is often started at the time of the hand solder.

5. Repairing

Repair should not be done after the LEDs have been soldered. When repairing is unavoidable, a double-head soldering iron should be used (as below figure). It should be confirmed beforehand whether the characteristics of the LEDs will or will not be damaged by repairing.

